

超出铁壳上表面  
面0.10mm Max

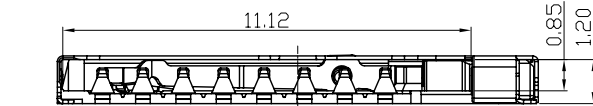
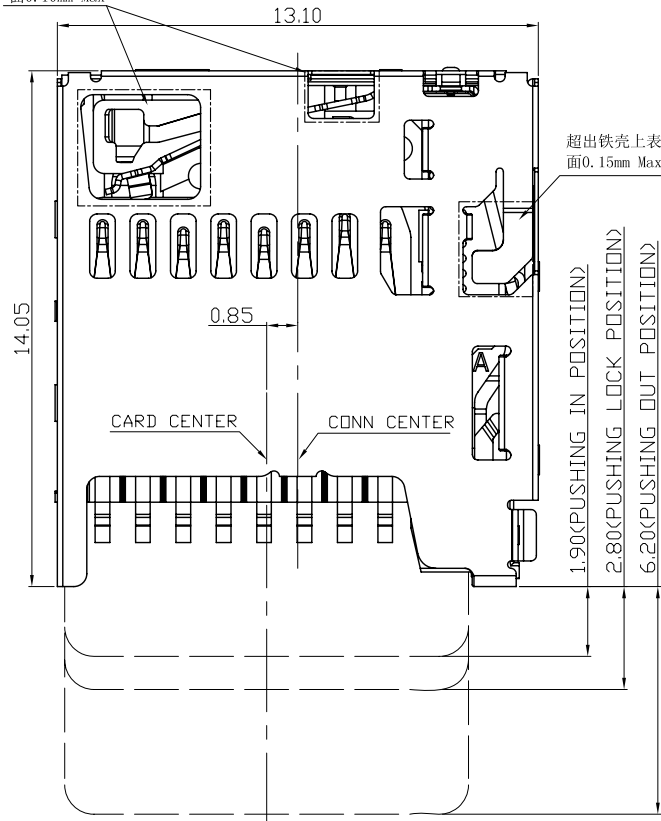

PART.NO.:  
MR120-AP401-\*\*\*

- 42: 功能区镀金10 $\mu$ , 锡脚镀雾纯锡至少100 $\mu$
- 43: 功能区镀金30 $\mu$ , 锡脚镀雾纯锡至少100 $\mu$
- 44: 功能区镀金50 $\mu$ , 锡脚镀雾纯锡至少100 $\mu$
- 45: 功能区镀金100 $\mu$ , 锡脚镀雾纯锡至少100 $\mu$
- 46: 功能区镀金150 $\mu$ , 锡脚镀雾纯锡至少100 $\mu$
- 47: 功能区镀金300 $\mu$ , 锡脚镀雾纯锡至少100 $\mu$

NOTES :

1. MATERIAL :
  - 1.1 HOUSING: LCP UL94 V-0, BLACK COLOR.
  - 1.2 SHELL: STAINLESS STEEL
  - 1.3 CONTACT: PHOSPHOR BRONZE.
2. FINISH :
  - 2.1 CONTACT: GOLD PLATING ON CONTACT AREA,  
MATTE TIN 100 $\mu$ MIN ON SOLDER TAIL AREA.  
50 $\mu$  MIN NICKEL PLATING OVERALL.
  - 2.2 SHELL: 30 $\mu$  MIN NICKEL PLATING OVERALL.  
Au 1 $\mu$ MIN ON SOLDER TAIL AREA.
3. ELECTRICAL CHARACTERISTICS:
  - 3.1 OPERATING VOLTAGE : 100V AC(rms)/DC.
  - 3.2 CURRENT RATING : 0.5 A.
  - 3.3 OPERATING TEMPERATURE: -25 $^{\circ}$ C~+85 $^{\circ}$ C.
  - 3.4 CONTACT RESISTANCE: 100 m OHMS MAX.
  - 3.5 INSULATION RESISTANCE: 1000M OHMS MIN. AT 250VDC.
  - 3.6 DIELECTRIC WITHSTANDING VOLTAGE:500 VAC/1MINUTE.
  - 3.7 MATING CYCLES: 7000 CYCLES.

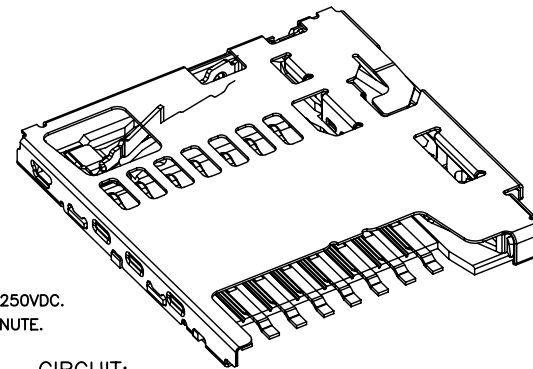

CIRCUIT:

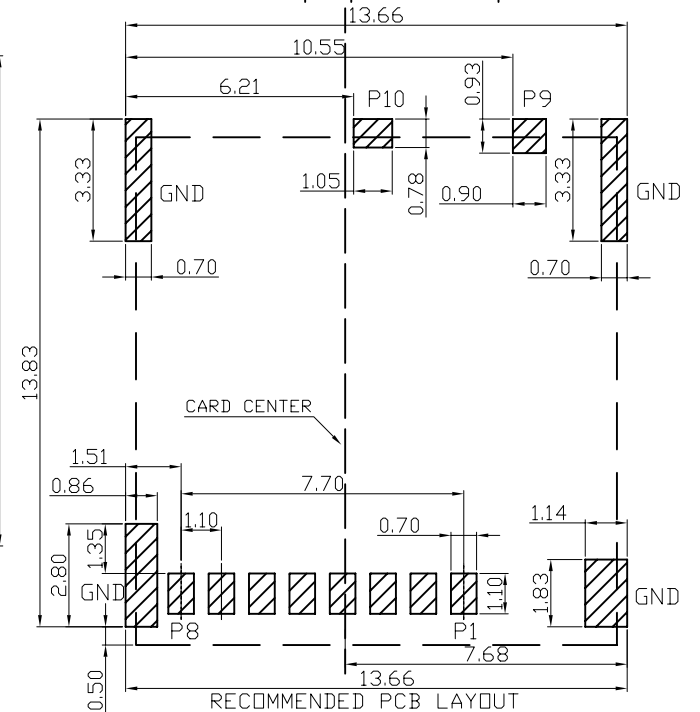
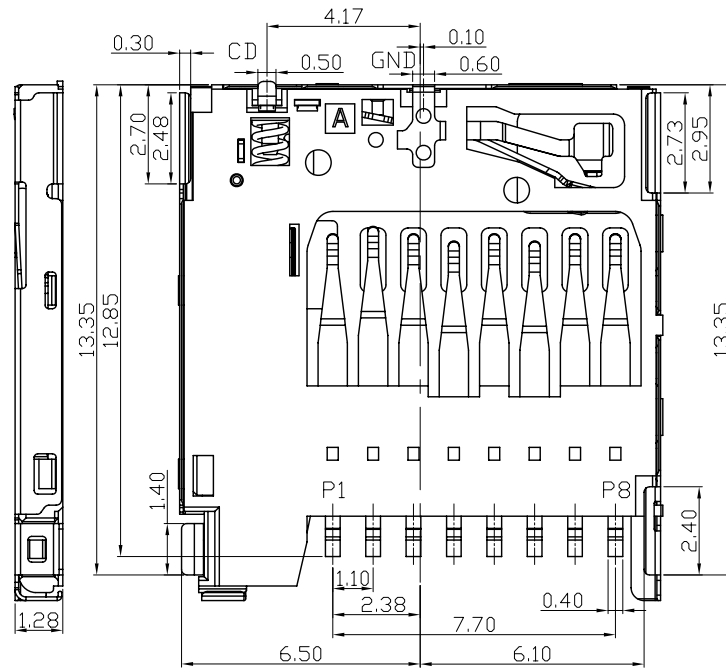
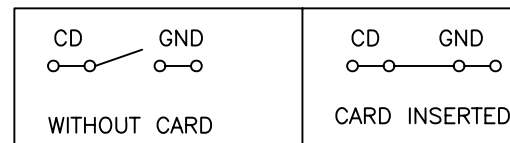

RECOMMENDED PCB LAYOUT  
(ALL TOLERANCE ARE  $\pm 0.05$ )

Pin No.	MICRO SD
PIN1	DAT2 1P
PIN2	DAT3 2P
PIN3	CMD 3P
PIN4	VDD 4P
PIN5	CLK 5P
PIN6	VSS 6P
PIN7	DAT0 7P
PIN8	DAT1 8P
CD	CARD DETECT
GND	GROUND

GENERAL TOLERANCE	DWG.NO.	MR120-AP401-00	PART.NO.	MR120-AP401-***	DRAWN	L.M.J 2017.12.02	UNIT	mm	SCALE	1:1
x. $\pm 0.50$	REV.	A	TITLE	Micro SD Push H1.28 conn	CHECKED		东莞市欧联电子科技有限公司 DONGGUAN OLN ELECTRONICS TECHNOLOGY CO., LTD.			
.x $\pm 0.25$	SIZE	A4	SHEET	1 OF 2	APPROVED					
.xx $\pm 0.15$	A4									

# 东莞市欧联电子科技有限公司

## 包装作业规范

REV.	ECN.NO.	MODIFY.CONTENT
------	---------	----------------

### 包装作业图示及说明

### (PACKING OPERATION DIAGRAM & INSTRUCTION)

- 一.
- 1) 将成品一一放入REEL包装盘内,依同一方向放入.
  - 2) 包装时,如下图所示,放置 2400 个成品.

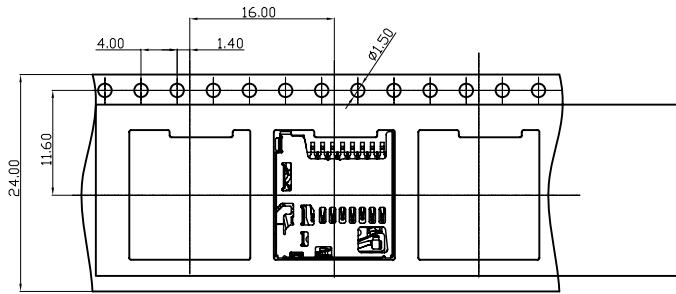

- 二.
- 1) 装盘前先把前面空15pcs产品,然后再开始装盘,尾端也需空出27pcs产品,上带加长200mm.
  - 2) 装满成品的REEL包装盘如下图所示.
  - 3) 一个REEL包装盘放置 2400 个成品.

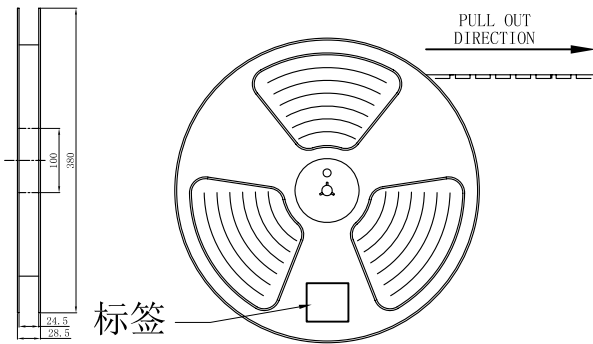

- 三.
- 1) 每箱装 10 盘REEL包装盘.
  - 2) 每箱放置2400PCS 的成品.

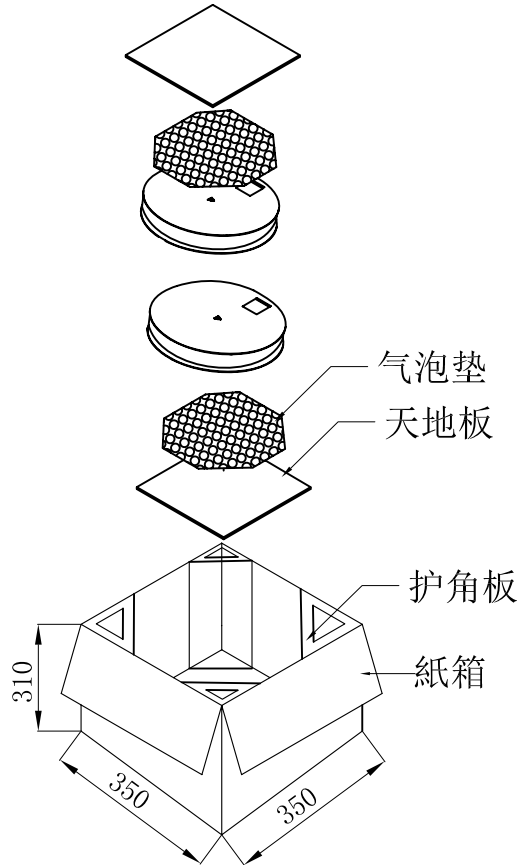

- 四.
- 1) 用TAPE将纸箱封实.

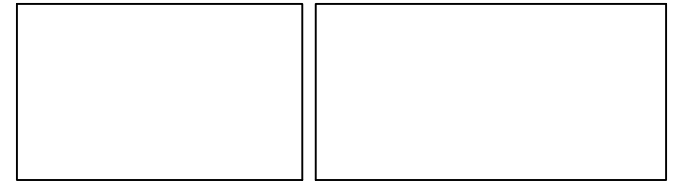

### 備註 (REMARK)

1. 若有未装满之零数箱,必须以缓冲材塞满.

GENERAL TOLERANCE	DWG.NO.	MR120-AP401-00	PART.NO.	MR120-AP401-**	DRAWN	L.M.J 2017.12.02
x.±0.50	REV.	A	TITLE	Micro SD Push H1.28 conn	CHECKED	
.x±0.25	SIZE	A4	SHEET	2 OF 2	APPROVED	
.xx±0.15						

UNIT	mm	SCALE	1:1
东莞市欧联电子科技有限公司 DONGGUAN OLN ELECTRONICS TECHNOLOGY CO., LTD.			